



GREENFIELD
WATER SOLUTIONS

TURBO DESCALER Installation Manual

WATER CONDITIONING WITH ADVANCED TECHNOLOGIES



TECH SUPPORT: 253-887-1265

Designed By Aquametrics USA

Patent Pending

FCC Approved

Three Year Warranty

Packing List:

- Turbo Descaler in an aluminum housing
- Aquametrics AC/DC Adapter (power supply)- **Do not substitute other power adapters!**
- AC Power Cord
- AC Outlet Tester
- Blue wire with flat connector on one end and a plug on the other end
- Residential Quick Start Guide and signal light key. (Tag on cord)
- Pipe clamp with terminal connection for blue wire.
- Turbo Descaler Installation Manual
- Pipe Ties (2)
- Mounting Screws (4)
- Warranty Card

INSTALLING THE TURBO DESCALER

Provided pipe clamp is for pipes up to 1" – for larger pipes, similar style clamps are readily available in larger sizes at your local hardware store.



FIG. 1 : AC Outlet Tester



proper pipe clamp attachment

TEST ELECTRICAL OUTLET FIRST

The Turbo Descaler will only work with a properly wired three-prong type electrical outlet. Test the AC outlet with provided tester (See **FIG. 1**) before plugging in the Turbo Descaler. If you use an extension cord, be sure to test its three-pronged AC outlet plug as well.

Plug in the AC tester. Electrical outlets conforming to the Uniform Electrical Code will show two yellow lights and no red light. If any different light configuration appears, there is a wiring problem with that outlet that should be fixed by a qualified electrician. Test another outlet for possible use.

If the hot water heater has braided lines or plastic hoses, do not connect to them; you can change the braided lines to copper corrugated supply lines or select another pipe location.



Rubber insert

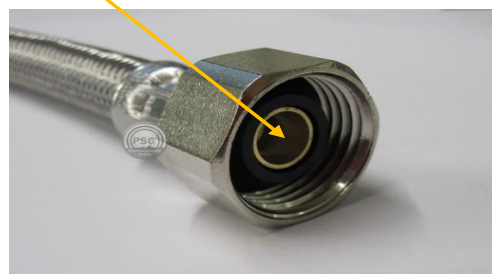

BRAIDED SUPPLY LINES – DO NOT USE!

The **copper** corrugated supply lines are the semi-flexible lines on the top of the hot water heater. These curved lines are often covered by heat insulating foam or similar material. Make your connection for the pipe clamp and the blue wire here. (**Figure 1,2,3**) (Stainless corrugated connectors are also available but don't transfer the signal as well)



Figure 1



Figure 2



Figure 3

POWER HOOK UP OF THE TURBO DESCALER™

1. Plug the "Output Cord" into the Turbo Descaler "Rear Panel." See FIG. 4
2. Plug the provided with the Turbo Descaler "AC Power Cord" into the "AC/DC Adapter." See Fig 5
3. Plug the "AC Power Cord" into the pre-tested AC electrical outlet. The output signal lights will flash for a few seconds.
4. **All 8 "Signal Level" blue lights on the front panel will sequence.. This light pattern will continue to repeat.** The "Power" light will be on. The "Fault" light will be off. See FIG.6 (See the hanging tag for front panel light key)
5. Test your piping system for an appropriate connection point for the Turbo Descaler. Usually the best location is the (cold or hot) copper pipe.

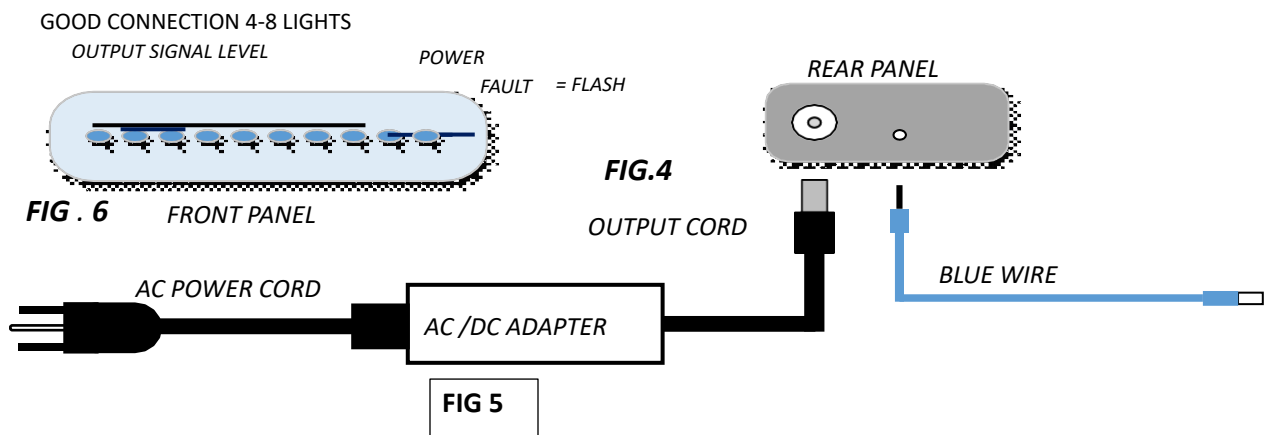

INSTALLATION OF THE TURBO DESCALER

1. If available connect Turbo Descaler to the corrugated copper supply line of the water heater(HOT OR COLD).
2. If copper corrugated lines are not available, then test a rigid metal water supply lines or other metal pipes in the system. Usually the main feed to the home will work. To test for appropriate connection points, touch the flat metal end on the pipe for a good connection point. [If a good connection cannot be made refer to page A of Trouble shooting](#)
3. If the fault light is not flashing on, then that is a good place to connect the Turbo Descaler. **The 8 lights will continue to flash sequentially** , If less than 8 sequentially flashing output signal lights are shown the unit is still working but not to the total capacity. Try several locations to find the optimum location. The Turbo Descaler will successfully descale as long as the fault LED (**far right of display Fig 6**) is not flashing. The location with the most “**signal level lights**” sequencing across the front panel is the best location.

Congratulations, Your Turbo Descaler has been successfully installed, self-tested and is fully operational.

Page A

Descaler Troubleshooting Guide

Grounds or ground loops are problems for all electronic descaling devices. The Turbo Descaler's front panel will help you find the best solution to an AC ground problem.

Some residential and commercial plumbing systems have AC grounded pipes, which may prevent any Descaler from sending a descaling signal into the water. Fortunately, you have a Turbo Descaler, which can identify ground problems, enabling you to fix grounding problem with simple tools.

DIY Guide to Installing a Short Section of Metal Pipe for ideal Turbo Descaler connection.

The Turbo Descaler only needs a short section of non AC grounded metal pipe to transmit the descaling signal into the water. The descaling signal will then travel through the water of plastic (PEX, PVCV) or metal pipe to do its descaling.

1. The diagram below illustrates an “**ideal connection pipe**” that allows the Turbo Descaling signal to effectively enter the water of the plumbing system.

<https://www.freshwatersystems.com/c-283-seatech-35-series.aspx>

Part number for ¾” is 3514-14

Part number for 1 “ is 3515-18

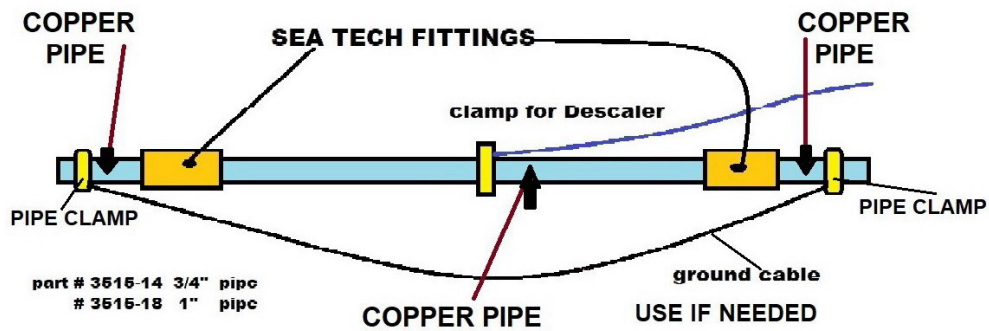

Use the Sea Tech fittings isolates the pipe from the ground. If a ground is needed simply put a jumper on the pipe from one side to the other leaving the center pipe for the connection to the Descaler

The installation requires a pipe cutter and pipe sealant available at your local hardware or plumbing supply outlet. Installation steps:

- Turn off water.
- Depressurize water pipes by running water at a faucet.
- Cut and remove an 8-12 inch section of pipe. You may need a bucket and towels. Be sure there at least 2" of pipe to connect to at both ends. Remove debris from cut pipe ends..
- Push fitting on to both ends of cut pipe then replace pipe.
- Make the Turbo Descaler connection on this pipe with the clamp provided.
- Turn on water and check for leaks.

PERFORMANCE WARRANTY: Our commitment to high quality, exemplary service and complete customer satisfaction is unsurpassed. We offer an incredible One Year Performance Warranty along with a Three-Year Manufacturer's Warranty.

MANUFACTURERS WARRANTY: The Turbo Descaler performs a self-test about every 10 seconds. Should the self-test fail during the first three years of operation the Turbo Descaler will be replaced or repaired free of charge. This warranty does not affect the consumer's statutory rights and does not include shipping costs.

DISCLAIMER: (1) Aquametrics does not accept any responsibility for water leaks that may occur by the removal of limescale or for any losses arising from the use of its water conditioners. (2) The Turbo Descaler has not been tested in hospital or other medical applications.